



# VMIVME-4116

## 8-Channel 16-bit Resolution Analog Output Board

- 8 channels
- 16-bit DACs
- Fast settling: 10  $\mu$ s maximum to  $\pm 0.003$  percent of FSR
- Buffered voltage output ( $\pm 10$  V at 5 mA)
- Multiplexed programmable outputs on P2 connector for testing analog outputs
- Double-buffered data latches
- Jumper-selectable synchronized update control
- Selectable external update control input or software-controlled strobe provides single update strobe for all DAC outputs
- Front panel fail LED
- High reliability DIN-type output connector
- Outputs set to 0.0 V on power up
  - Outputs are automatically disconnected from the field at power up
- Double Eurocard form factor
- Supports VMIC's analog expansion and Built-in-Test bus (AMXbus™) that interconnects the P2 connectors of various VMIC ADC and DAC boards and expansion multiplexer boards
- Multiplexed programmable outputs for testing analog input multiplexer boards
  - Requires VMIC ADC board and AMXbus for Built-In-Test

**INTRODUCTION** — The VMIVME-4116 Digital-to-Analog Converter (DAC) Board performs digital-to-analog conversion on 16-bit positive true offset binary or two's complement coded words, with an analog output range of -10 to +10 V. This provides for a resolution of 305  $\mu$ V for each digital input of 1 LSB change. The buffered output voltage settles to within 1/2 LSB in 10  $\mu$ s.

The DAC offers a Digital-to-Analog Integrated Circuit (IC) per channel. A Control and Status Register (CSR) is loaded by the processor and this register controls the functioning of the board. The CSR can be read by the processor at any time. The VMIVME-4116 board functional block diagram is shown in Figure 1. Each of the eight DACs is preceded by double-buffered data latches. The data latches allow versatility in the way the DAC analog output may be updated.

There are three methods by which new data can be converted by a DAC. Each method is enabled/disabled by on-board jumpers and is further controlled by a CSR that must be loaded by the user.

### FUNCTIONAL CHARACTERISTICS

**Compatibility:** The VMIVME-4116 Analog Output Board is a standard, double height, printed circuit board which is compatible with the VMEbus specification.

**Board Address:** The physical address for the board is selected by 12 DIP switches. VMEbus address lines A05 through A15 are decoded for board selection.

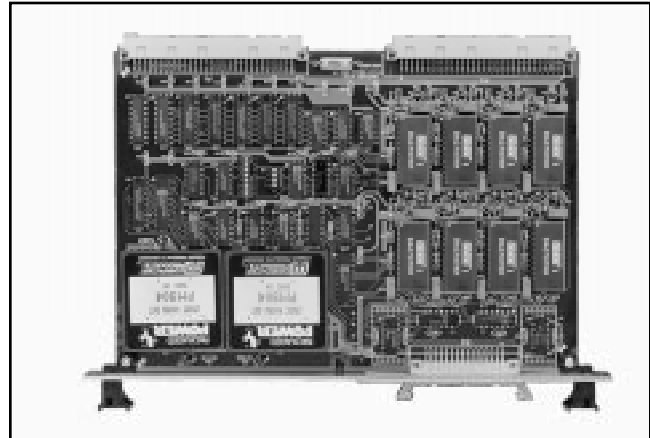

**VMEbus Access:** Address modifier bits are jumper-selectable to support nonprivileged short I/O or supervisory short I/O access. The board is factory configured for supervisory short I/O access.

**Data Transfer:** Data can be written to one of the eight Digital-to-Analog Converters (DACs) in bytes or words (via data bits D00 through D15). Bipolar operation (-10 to +10 V output) uses offset binary coding or two's complement binary coding.

Ordering Options	
August 13, 1996 800-004116-000 E	
VMIVME-4116	
Description	Model Number
	0 to $\pm 10$ V Outputs
8-Channel, Double-Buffered, 16-bit Analog Output without Built-in-Test and without Output Isolation	VMIVME-4116-070
8-Channel, Double-Buffered, 16-bit Analog Output with JFET Output Isolation Switches and Built-in-Test Hardware	VMIVME-4116-060
8-Channel, Double-Buffered, 16-bit Analog Output with Output Isolation Relays and Built-in-Test Hardware	VMIVME-4116-050
8-Channel, Double-Buffered, 16-bit Analog Output with JFET Output Isolation Switches and No Built-in-Test Hardware	VMIVME-4116-040
8-Channel, Double-Buffered, 16-bit Analog Output with Output Isolation Relays and No Built-in-Test Hardware	VMIVME-4116-030
Connector Data	
Compatible Cable Connector	Panduit No. 120-332-435E
Strain Relief	Panduit No. 100-000-042
PC Board Header Connector	Panduit No. 120-332-033A
<p><b>For Ordering Information, Call:</b>            1-800-322-3616 or 1-256-880-0444 • FAX (256) 882-0859            E-mail: info@vmic.com Web Address: www.vmic.com            Copyright © July 1986 by VMIC            Specifications subject to change without notice.</p>	

**Mode Selection:** The operational modes of the board are selected by setting the following control bits during a write cycle to the Control and Status Register (CSR). The CSR may be read at any time to verify the current operating mode. The function of each bit in the CSR is defined as follows.

D08	—	Enables DAC outputs to the P3 connector
D09	—	Initiates digital-to-analog conversion
D10	—	Not used
D11 to D13	—	Test mode control bits
D14	—	Operates Fail LED
D15	—	Not used

**Test Mode:** The DAC board may be used in conjunction with other VMIC boards and VMIC's AMXbus backplane for extensive fault detection and isolation. There are two dedicated analog signal lines that are used by the DAC board. Loopback tests may be executed primarily for testing the Analog-to-Digital Converter (ADC) board by utilizing any one of the eight DAC outputs.

While in a test mode, the eight DAC outputs may be isolated from the P3 output connector so that user-connected devices are not affected by testing. Also, the testing may be performed in conjunction with real-time control of the user-connected devices, providing real-time fault detection capabilities.

**Analog Input Test Mode:** Any one of the eight analog outputs may be multiplexed to an analog test bus (Test Bus 1). This analog bus is used to verify the operation of the analog input multiplexer expansion board that supports Built-in-Test. VMIC's AMXbus supports the analog Built-in-Test concepts.

**Analog Output Testing:** Any one of the eight analog outputs may be switched to the analog output test bus (Test Bus 2). This bus is routed over the P2 AMXbus analog backplane to a VMIC ADC which verifies the analog output of each of the eight DACs on the VMIVME-4116 board.

**System Reset:** Application of the system reset signal via the VMEbus initializes the board into a state with all analog outputs disconnected from the P3 connector if either the JFET switch or output isolation relay options are installed. If no output isolation switches or relays are installed (see the Ordering Options), then system

reset initializes all analog outputs to the P3 connector to 0.0 V. The analog test bus outputs are disconnected from the P2 connector upon system reset.

**Front Panel Fail LED:** If an error condition is detected during the diagnostics, a front panel Fail LED may be illuminated under software control for a visual failure indication. The LED is illuminated upon power up clear (system reset) and is extinguished upon successful diagnostic execution.

**Analog Output Channels:** Eight analog output channels

The analog output equation for offset binary bipolar operation:  
 (-10 V to +10 V) is  $V_{OUT} = -10 V + \frac{[(\text{Digital Code } 10 \times 20)]}{65536}$

## ELECTRICAL CHARACTERISTICS

**Data Transfer:** A16/D8, D16

**Analog Output (Voltage output at  $R_{LOAD} = 2 \text{ k}\Omega$ ):**

Bipolar: -10 to +10 V at 5 mA

**Output Impedance:**

Standard model — 0.15  $\Omega$

Optional output isolation switches (JFET switch)  
 —100  $\Omega$

Optional output isolation relays — 0.2  $\Omega$

**D/A Input Code:**

Bipolar: Offset binary, two's complement binary

**Resolution:** 16 bits

**Accuracy (Typical at 25 °C)\***

Gain Error: Adjusted to  $\pm 1/2$  LSB

Offset:

Bipolar: Adjusted to  $\pm 1/2$  LSB

Differential Linearity Error:  $\pm 0.003$  percent of FSR (Full-Scale Range)

**Linearity Error:**  $\pm 0.0015$  percent of FSR

**Drift (Typical Unless Otherwise Stated):**

Gain Drift:  $\pm 10$  PPM/ $^{\circ}\text{C}$

Zero Drift:  $\pm 5$  PPM of FSR/ $^{\circ}\text{C}$

Differential Linearity Over Temperature:  
+0.009 to -0.006 percent of FSR (maximum)

Linearity Error Over Temperature: ±0.006 percent  
of FSR (maximum)

**Settling Time:** 10 µs to ±1/2 LSB

**Monotonicity:** 14 bits monotonic over full  
temperature range

**Power Requirements:** 2.5 A (maximum) at +5 V

**PHYSICAL/ENVIRONMENTAL**

**Temperature:** 0 to +50 °C, operating  
-20 to +85 °C, storage

**Humidity:** 20 to 80 percent relative, noncondensing

**Altitude:** Operation to 10,000 ft

**Cooling:** Forced air convection

**Dimensions:** Double height Eurocard (6U) 160 x  
233.35 mm

**VMEbus Connector:** Two 96-pin DIN connectors.  
VMIC utilizes the user I/O pins on the P2 connector to  
support an analog bus (AMXbus). A variety of

AMXbus backplanes are available from VMIC as  
standard products.

**Output Connector:** Board connector (P3) —  
Panduit male connector type 120-332-033A  
Output cable connector — female type  
120-332-435E  
Output connector strain relief 100-000-042

**TRADEMARKS**

AMXbus is a trademark of and the VMIC logo is a  
registered trademark of VMIC. Other registered trademarks  
are the property of their respective owners.

---

\*Accuracy stated without analog output isolation switches  
installed. The Built-in-Test hardware features analog output  
isolation switches for all eight channels that can be turned  
ON/OFF by software commands. These switches are in a series  
with the analog output and the user-connected device at the P3  
connector. These switches have an ON resistance of  
approximately 100 Ω (maximum). If the user-connected load  
does not have a high impedance input, then a possible voltage  
division error is introduced. For example, if R(Load) is 10 kΩ,  
then a 1 percent error is introduced. R(Load) should be 10 MΩ  
or greater for an error of 0.001 percent or less.

**APPLICATION AND CONFIGURATION GUIDES** — The following Application and Configuration Guides are available  
from VMIC to assist the user in the selection, specification, and implementation of systems based in VMIC’s products.

Title	Document No.
Digital Input Board Application Guide	825-000000-000
Change-of-State Board Application Guide	825-000000-002
Digital I/O (with Built-in-Test) Product Line Description	825-000000-003
Synchro/Resolver (Built-in-Test) Subsystem Configuration Guide	825-000000-004
Analog I/O Products (with Built-in-Test) Configuration Guide	825-000000-005
Connector and I/O Cable Application Guide	825-000000-006
Data Acquisition Noise Reduction	825-000000-026



systemerra computer GmbH • Kreuzberger Ring 22  
D-65205 Wiesbaden • +49 (0) 611 9748 470  
info@systemerra.de • www.systemerra.de

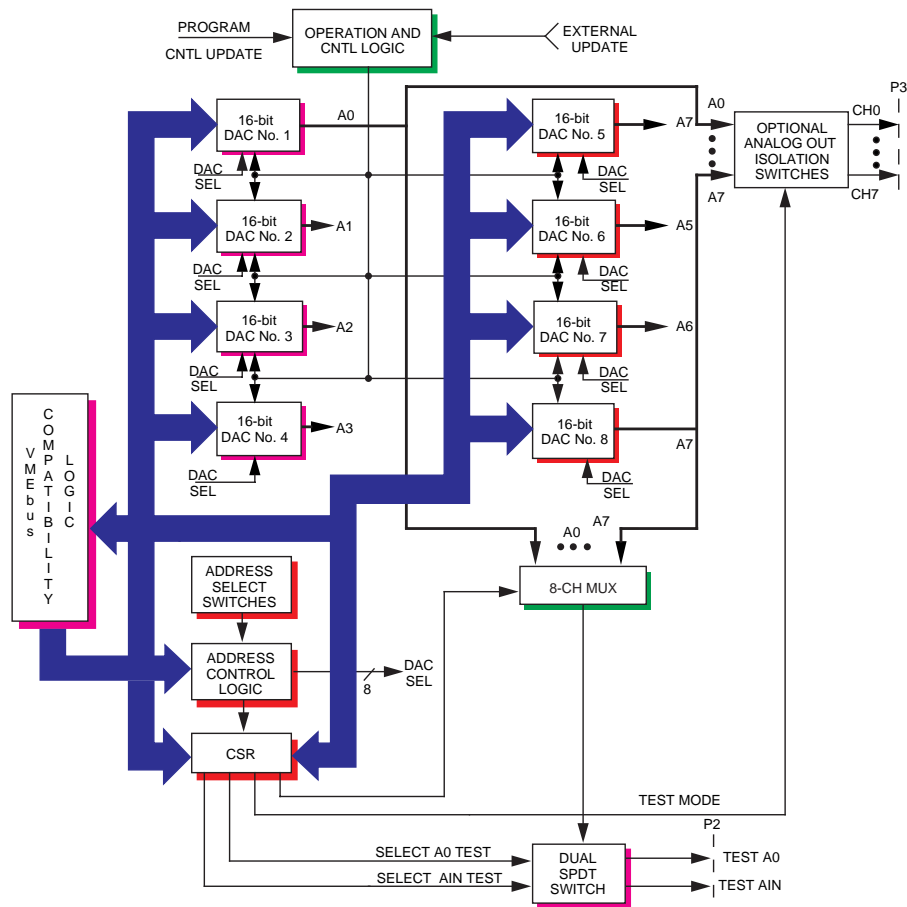
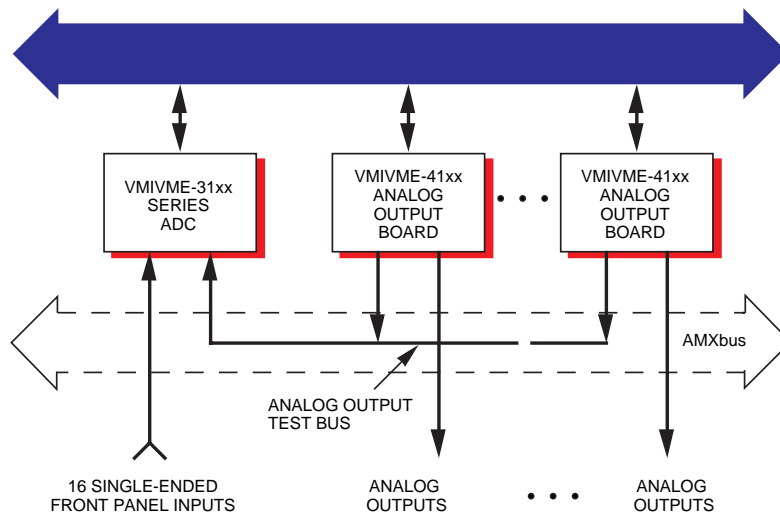

Figure 1. VMIVME-4116 Board Functional Block Diagram



The AMXbus backplane may be replaced with a standard P2 VME expansion bus and user-supplied jumper wires on the user I/O pins. The VMIC AMXbus backplane is available in printed circuit form in 5, 9, or 19 slots. The AMXbus backplane is designed to provide enhanced noise immunity and is recommended for most applications.

Figure 2. Model 41xx Series Built-in-Test Configuration